

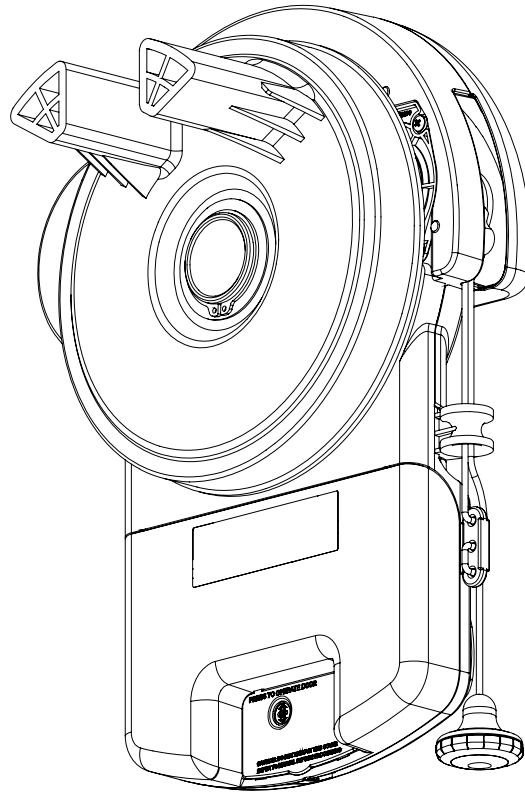

GDO-6v3 EasyRoller[®]

Roll Up Garage Door Opener



Featuring **TrioCode[™]** Technology

aut^omatic
TECHNOLOGY

smart | simple | secure



WARNING: It is vital for the safety of persons to follow all instructions. Failure to comply with the installation instructions and the safety warnings may result in serious personal injury and/or property and remote control opener damage. Please save these instructions for future reference.

Automatic Technology Australia Pty Ltd to the extent that such may be lawfully excluded hereby expressly disclaims all conditions or warranties, statutory or otherwise which may be implied by laws as conditions or warranties of purchase of an Automatic Technology Australia Pty Ltd Garage Door Opener. Automatic Technology Australia Pty Ltd hereby further expressly excludes all or any liability for any injury, damage, cost, expense or claim whatsoever suffered by any person as a result whether directly or indirectly from failure to install the Automatic Technology Australia Pty Ltd Garage Door Opener in accordance with these installation instructions.



GDO-6v3 EasyRoller®

Roll Up Garage Door Opener

Important Safety Instructions	4
Features	6
Operating Controls	8
Package Contents	10
Installation	11
Pre-Installation Requirements	11
Installation	12
Programming the Opener	15
Setting Limits	15
Setting Limits: via Transmitter	16
Safety Obstruction Force	17
Safety Obstruction Force Test	17
Adjusting Safety Obstruction Forces	18
Coding Transmitters	19
Door	19
Courtesy Light	19
Pet (Pedestrian) Mode	19
Vacation Mode	19
Easy Access Transmitter Coding	20
Remotely Coding Transmitters	20
Deleting Transmitter Codes	21
Accessories	22
Photo Electric Beam	22
Auto-close	22
Final Set Up	23
Setting of Courtesy Light Time	23
Setting the Pet Mode Position	23
Wall Transmitter Installation	23
Reset all Factory Defaults	23
SmartSolar™ Installation	24
Battery Back Up Kit Installation	25
Parameters	26
Door Status Indicators	26
Button Functions	27
Default Settings & Specifications	28
Troubleshooting	29
Maintenance	30
Spare Parts	32
Warranty	34





Important Safety Instructions

WARNING: It is vital for the safety of persons to follow all instructions. Failure to comply with the following Safety Rules may result in serious personal injury and/or property damage.

CAUTION: If your garage has no pedestrian entrance door, an emergency access device should be installed. This accessory allows manual operation of the garage door from outside in case of power failure.

For **ADDITIONAL SAFETY** protection we **STRONGLY** recommend the fitting of a Photo Electric (P.E.) Beam. In most countries P.E. Beams are mandatory on all garage doors fitted with automatic openers. For a small additional outlay Automatic Technology recommends that Photo Electric Beams be installed with the automatic opener ensuring additional safety and peace of mind.

DO NOT operate the opener unless the garage door is in full view and free from objects such as cars and children/people. Make sure that the door has finished moving before entering or leaving the garage.

DO NOT operate the opener when children/persons are near the door. Children must be supervised at all times when the EasyRoller® is in use. **Serious personal injury** and/or property damage can result from failure to follow this warning.

DO NOT allow children to operate the EasyRoller®. **Serious personal injury** and/or property damage can result from failure to follow this warning.

Regularly check to make sure that the **safety obstruction force** is working correctly, and is **tested** and set as per **page 17 of this manual**. Failure to follow these instructions could result in **serious personal injury** and/or property damage. This test must be repeated at regular intervals and the necessary adjustments made as required.

Doors requiring over 400N of force to move must have P.E. Beams installed.

DO NOT disengage the door opener to manual operation with children/persons or any other objects including motor vehicles within the doorway.

The door opener is not intended for use by young children or infirm persons without adequate supervision. Children should be supervised to ensure that they do not play with the remote transmitters or the opener.

Keep hands and loose clothing **clear** of the door and door opener at all times.



Important Safety Instructions

The unit should be installed so that it is protected from the elements. It should not be exposed to water or rain. It is not to be immersed in water or sprayed directly by a hose or other device.

The garage door must be **well balanced**. Sticking or binding doors must be repaired by a qualified garage door installer prior to installation of the opener.

Frequently examine the installation, in particular cables, springs and mountings for signs of wear, damage or imbalance. **DO NOT** use if repair or adjustment is needed since a fault in the installation or an incorrectly balanced door may cause injury. **DO NOT** attempt to repair the door yourself as hardware is under extreme tension.

Remove or disengage all garage door locks and mechanisms prior to installation of the opener.

Connect the opener to a properly **earthed** general purpose 240V mains power outlet installed by a qualified electrical contractor.

Disconnect the power cord from mains power before making any repairs or removing covers. Only **experienced** service personnel should remove covers from the opener.

When using auto close mode, a **photo electric beam** must be fitted correctly and tested for operation at regular intervals. **Extreme caution** is recommended when using auto close mode. **All safety rules** must be followed.

In order for the EasyRoller® to **sense** an object obstructing the door way, some **force** must be exerted on the object. As a result the object, door and/or person may suffer **damage** or **injury**.

If the power supply cord is damaged, it **must** be replaced by an Automatic Technology service agent or suitably qualified person.

Make sure that the door is fully open before driving in or out of the garage and fully closed before leaving the driveway.

Make sure that remote controls are kept out of reach of children.

Install the wall switch or wall mounted transmitter in a location where it is out of reach of children and the garage door is visible.





Features

Thank you for purchasing the Automatic Technology EasyRoller® Automatic Garage Door Opener. Designed by our renowned engineers to suit sectional overhead and one piece tilt up doors, the EasyRoller® will provide years of smart, simple & secure convenience to your home.

Operation

To open or close the door simply press a button on a TrioCode™ handheld transmitter, a wall mounted transmitter, or optional wall switch for two seconds. During open and close cycles the door can be stopped by pressing the button again. The next actuation will move the reverse the door's direction.

TrioCode™ Code Hopping Technology

Every time a TrioCode™ transmitter is used a new security code is randomly generated from over 4.29 billion possibilities. This greatly enhances the security of the system and makes "code grabbing" a thing of the past

These transmitters also overcome interference issues by simultaneously sending a signal over three slightly different frequencies. Even if two of the three signals are jammed, the system will still work.

ALPS (Automatic Limits Positioning System)

ALPS does away with manual adjustment of the door's limits position using mechanical parts, such as cams and microswitches. During installation the hand held transmitter can be programmed to set the door limits positions.

ISS (intelligent safety obstruction system)

While the door is performing a close cycle, should it hit an obstacle or be restricted in some manner, it will automatically reverse. The amount of force the door should encounter before reversing is automatically adjusted by the doors control system during the initial installation of the automatic door opener. The door will also stop if restricted whilst opening. The Safety Obstruction Force should be checked monthly.

Auto courtesy light

The courtesy light comes on automatically for three minutes whenever the door is activated. The light can also be operated independently of the door by coding a dedicated button on a transmitter.





SmartSolar™ and Battery Back Up Compatibility (optional)

The opener can be fitted with a SmartSolar™ or Battery Back Up kit for operation in the event of a power outage, or where mains power access is not available. **NOTE:** If the door is the only entrance to the garage, and a battery back up kit is not fitted, a keyed cable release should be fitted external to the garage.

Vacation mode

A hand held transmitter can be programmed to lock and unlock all other transmitters that have been programmed into the openers' memory. The vacation mode can be used when the door is left idle for long periods of time.

Pet/Pedestrian mode

The transmitter can be programmed to open the door to an adjustable partial height so that the family pet can enter and exit the garage at any time. You may also wish to open the door to a height suitable only for pedestrian access.

Auto-close mode

The opener can be programmed to automatically close after an open cycle. The auto-close time is adjustable. It is compulsory to install a P.E. Beam if this mode is selected, otherwise the door may cause personal injury or damage to property.

Photo Electric (P.E.) Beam (optional)

The opener has an input to connect a P.E. Beam for extra safety and use of the auto-close mode.

Manual operation

The opener is equipped with a unique manual disengaging device. If the power to the opener is disrupted the door can be put into manual mode by pulling down on the string handle on an angle towards the door. This allows for manual operation of the door. To re-engage the opener pull the string handle away from the door.

Easy Access Transmitter

Inside the manual release handle is a transmitter designed to be in easy reach so that the garage door can be operated without having to stretch to reach the operate button on the control panel.





Operating Controls

- 01 **P.E. Shunt.** The shunt has to be removed when connecting a Photo Electric Beam.
NOTE: P.E. Shunt must only be removed when P.E. Beams are being connected, otherwise the opener will malfunction.
- 02 **Terminal Block.**
 - 24V PWR is used to power devices such as:
 - » PE (Input) for photo electric beam for safety and auto-close function.
 - » LGT (Input) allow hard wired external trigger for the opener's courtesy light.
 - » O/S/C INPUT is used for the connection of a wired switch (momentary contact). This switch can then be used to open, stop or close the door. Install the wall switch in a location where the switch is out of reach of children and the garage door is visible.
- 03 **LIGHT CODE** button (white) is used for storing or erasing the transmitter button (code) you wish to use to switch the courtesy light on the opener on or off.
- 04 **CODING LED** (red) light flashes when a code is being stored or when a transmitter button is pressed.
- 05 **DOOR CODE** BUTTON (blue) is used for storing or erasing transmitter buttons for door operation
- 06 **DOOR STATUS LED** (Yellow)
- 07 **CLOSE** button (red) is used during installation to help set the close limit position. Pressing and holding this button will move the door in the close direction. Movement stops when the button is released.
NOTE: The safety obstruction detection is inoperable when the CLOSE button is used to move door..
- 08 **CLOSE LIMIT LED** (red) the LED is very helpful during installation. It illuminates and flashes when the door is closing and remains steady on when the close limit position has been reached.
- 09 **AUTO CLOSE TIME** button (White) is used to adjust the auto close time. While holding in the AUTO CLOSE TIME button and then pressing the open button the time is increased. Each press will increase the time by 5 seconds. Pressing the close button will decrease the time.
- 10 **FORCE MARGIN SET** Button The obstruction force margin is set automatically during installation. The margin can be adjusted manually using the Force Margin Set button (White). Holding the Force Margin Set button and pressing OPEN or CLOSE buttons will increase or decrease the amount of force. The Force Margin Set should only be used if environmental factors (wind, etc.) affect the door's operation.
- 11 **OPEN LIMIT LED** (green) the LED is very helpful during installation. It illuminates and flashes when the door is opening and remains steady on when the open limit position has been reached.
- 12 **OPEN** button (green) is used during installation to help set the open limit position. Pressing and holding this button will move the door in the open direction, releasing stops the door.
NOTE: The safety obstruction detection is inoperable when the OPEN button is used to move door.
- 13 **OPERATE** button (Yellow) is used during installation to test the open, stop and close cycles for the opener. The opener has to be initialised by the Reset button to make the O/S/C button operable.
- 14 **SET** button (yellow) is used during the installation phase together with the Open and Close buttons to set the door limit positions. The Set button is also used to re-initialize the Opener.



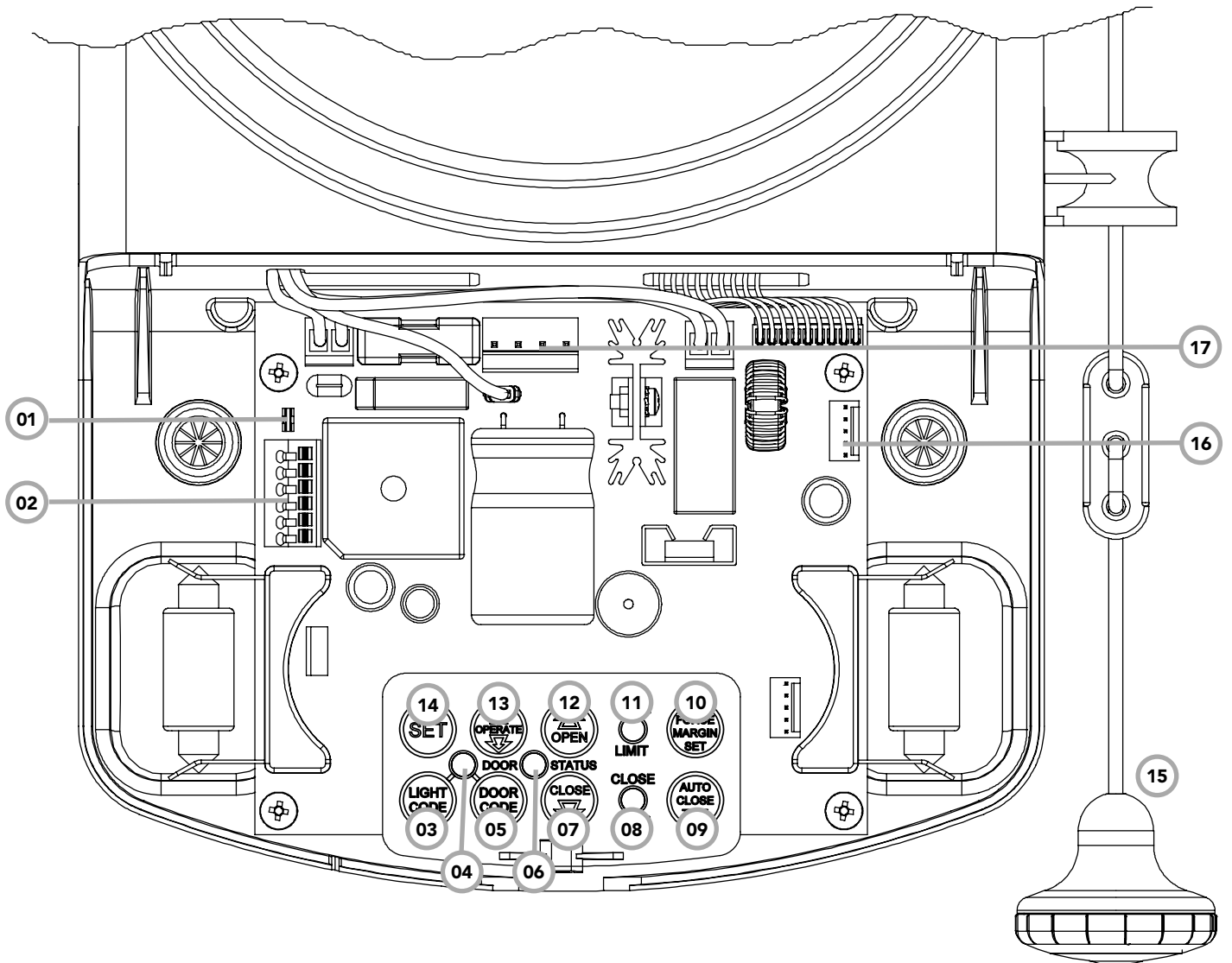

- 15 **ENGAGE/DISENGAGEMENT CORD** enables manual door operation, especially useful during power failures. At the cord's end is the **EASY ACCESS TRANSMITTER**; a wireless door controller.
- 16 **PROG INPUT** is used to connect the Automatic Technology Handheld Programmer for editing control and receiver functions, accessing diagnostic tools, and activating special features and operating modes.
- 17 **SBY-3 CONNECTOR** is used to connect both Battery Back Up Kits and SmartSolar™ kits.





Package Contents

GDO-6v3 Easyroller® drive unit w/ EAT	1
TrioCode™ keyring transmitters	2
Alkaline battery A23 12V	2
Screw #6 x 1"	2
Pan head screw M4x50mm (<i>not included in some models</i>)	2
Nilock hex nut M4 (<i>not included in some models</i>)	2
Flat washer I.D. 3/16 x 1/2 (<i>not included in some models</i>)	2
Locking bar covers	2
Weight bar (<i>not included in some models</i>)	1
Installation manual	1

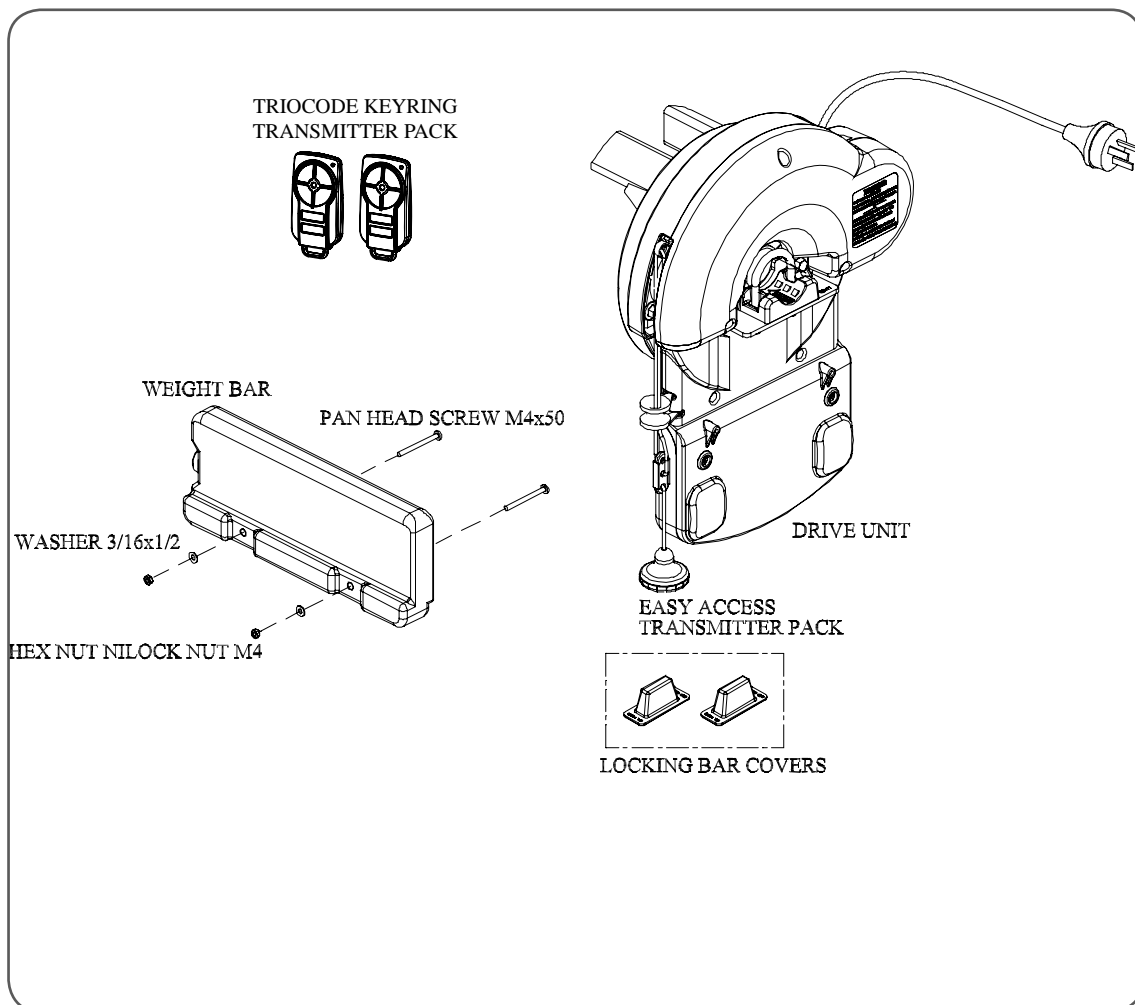



Pre-Installation Requirements



IMPORTANT SAFETY INSTRUCTIONS FOR INSTALLATION

Warning: Incorrect installation can lead to severe injury.
Follow ALL installation instructions.

Door Operation

The door must be in good operating condition. The maximum effort to move the door up or down, from stationary, should not exceed 200 Newtons (20kg force) at the bottom rail. The recommended force is 70N (7kg) for manual operation.

Lift the door to about halfway. When released, the door should stay in place supported entirely by its springs. Raise and lower the door to check for binding or sticking.

The door may need to be serviced to meet these requirements – refer to the door manufacturer’s servicing instructions or contact an authorised dealer.

Unsuitable Door Types

The fitting of an opener to doors with removable mullions is not recommended.



IMPORTANT NOTE - The opener should not be installed on any door incorporating a wicket door.

Position

The opener can be installed on either the right- or left hand side of the door (when viewed from inside the garage). The opener is factory set for right hand side installation.

This opener must be installed in a dry position that is protected from the weather. Moisture or corrosion damage is not covered by the Warranty.

Power Supply

Properly earthed 3 pin single-phase power is required.



WARNING! A portable power generator is not recommended. The opener may appear to malfunction due to spikes, surges and fluctuations in the generated voltage.

Side room

The minimum side room required from the edge of the door curtain is 40mm to the inside of the door bracket, and 85mm to the wall (**Fig. 01**). If a Battery Back Up Kit is to be fitted, at least 135mm to the bracket is required (**Fig. 01a**).

The recommended side room from the edge of the door curtain is 95mm to the inside of the door bracket, and 135mm to the wall (**Fig. 02**).

NOTE: Door Axle Diameter must not exceed 35mm.

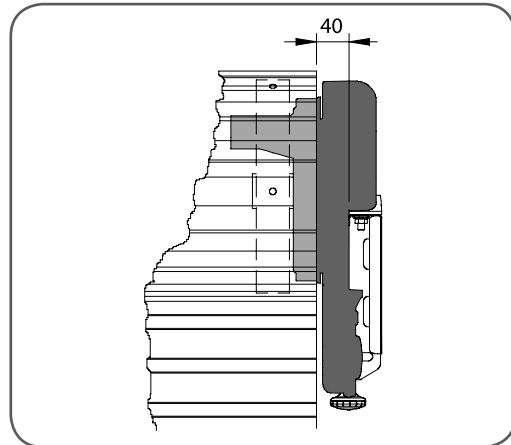

fig 01

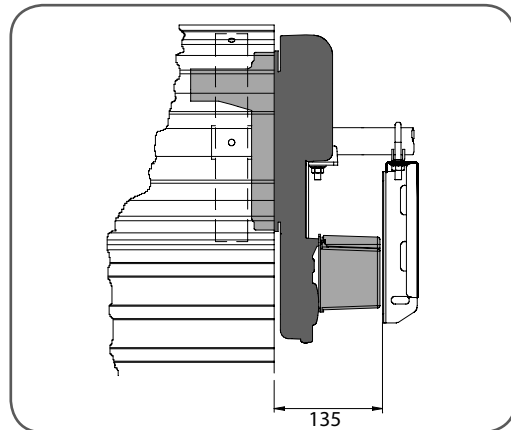

fig 01a

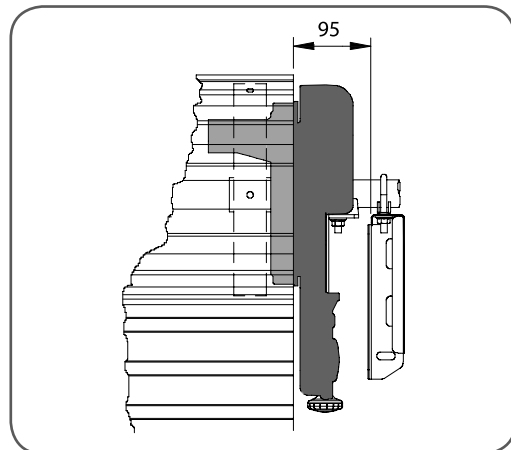

fig 02





Installation

fig 03

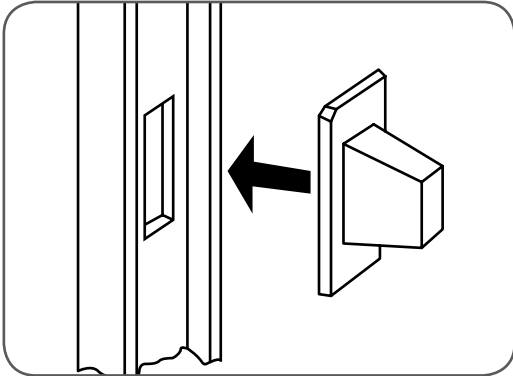

fig 04

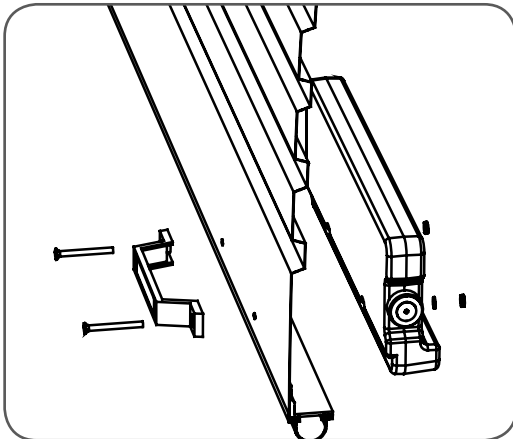

fig 05

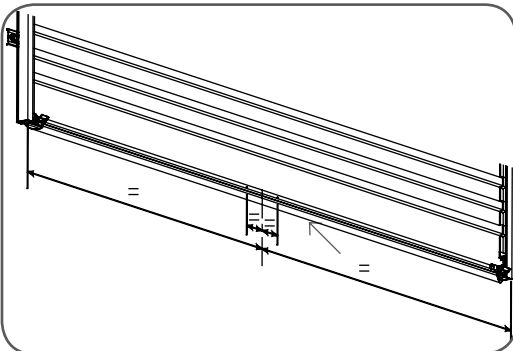
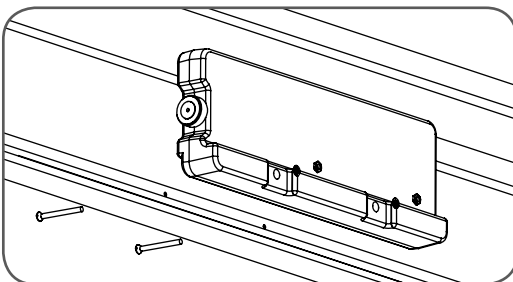

fig 06



Step 1 - Preparation

- a. Check the door's operation:
 - i. The door must travel smoothly and be easy to operate by hand.
 - ii. Operating force on the bottom rail should be approximately 70N (7kgs) force.
 - iii. Adjust any tight or twisted guides/tracks
 - iv. Clean the guides if there is any oil or wax present using a suitable white spirit. The only lubricant suitable for use on door guides is silicon spray. DO NOT use WD-40, RP-7, petroleum grease, or similar.
- b. Install the locking bar covers if there are locking bar holes in the guides. **(Fig.03)**



IMPORTANT NOTE - Do not lock your door with the locking bars after installing the opener. Remove or disable the lock using wire or cable ties. Security is not affected as the opener has an inbuilt locking facility.

- c. Affix the warning labels supplied with this opener in a prominent place where they are clearly visible.
- d. Choose the side where the opener will be installed ensuring there is sufficient sideroom.

Step 2 - Fit the Weight Bar

The weight bar must be fitted to the bottom-centre for proper operation of the opener.

If the door has a handle:

- a. Remove the door handle
- b. Fit the weight bar and refit the handle using the new fasteners provided **(Fig.04)**.

If the door does not have a handle:

- a. Locate the centre of the door at the bottom rail **(Fig.05)**.
- b. Place the weight bar at this point (there is a centreline marked on the weight bar) and mark the two positions where the fasteners will go
- c. Drill the two 4.5mm holes in the door and fit the weight bar using the new fasteners provided. **(Fig.06)**.

Check that the door is still balanced and smooth to operate. If it is not then the door may require servicing (refer to door manufacturer's instructions).



WARNING! The door and its springs are under significant tension. Adjustments should only be carried out by experienced persons, as this function can be dangerous if not performed under strict safety procedures.





Installation

Step 3 - Pin the Door Curtain

Pinning the door curtain to the door drum maintains security when the opener closes and locks.

- Fully close the door.
- Mark drill holes at both ends of the drum (**Fig. 07**).
- Drill holes using 3.2mm (1/8") drill bit. Open the door slightly for easier access, if necessary.
- Fit a 10 x 32mm screw and washer to each end. This screw should be positioned as low as possible, but make sure that it does not alter the curtain's normal approach to the guide (lead-in angle).

NOTE: Make sure that the screws do not project into the area where the internal gear will fit.

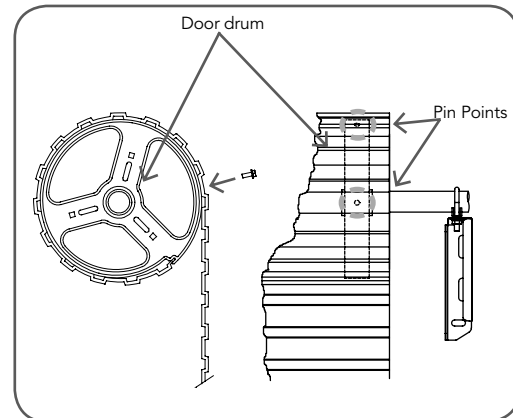

fig 07

Step 4 - Fitting the opener

- At the end opposite to where the opener will be fitted, check that the U-bolt is tightened securely. Fit the anti-coning collar (supplied) to the axle flush with the door drum.
- Open the door completely and tie safety ropes around the door roll approximately 300mm from each end. Do not tie the ropes too tight as damage to the curtain may ensue.
- At the end where the opener is to be fitted, support the door with a ladder or suitable prop:



WARNING! Make sure the support is snug under the door, are stable and will not move.

- At the end where the opener will be fitted use masking tape or pen to mark the position of the U-bolt in the door bracket and the position of the door bracket on the wall to assist in reassembling.
- Remove the U-bolt (or bolts) and saddle from the door bracket.
- Remove the door bracket allowing the door to rest on the support (**Fig. 08**).

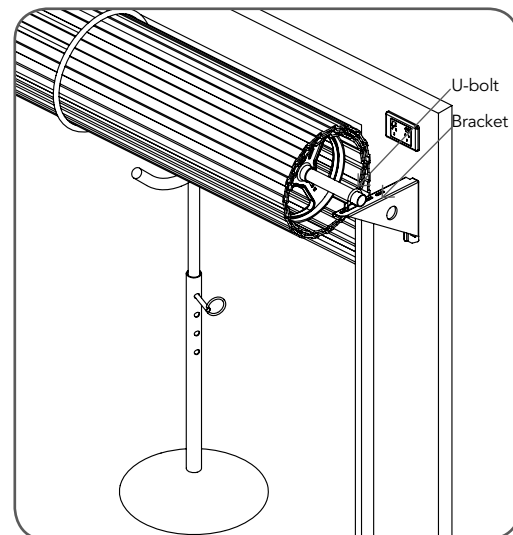

fig 08



NOTE - For minimum sideroom installations the door may have to be taken down.



WARNING! The opener must not be used with a door incorporating a wicket door.





Installation

fig 09

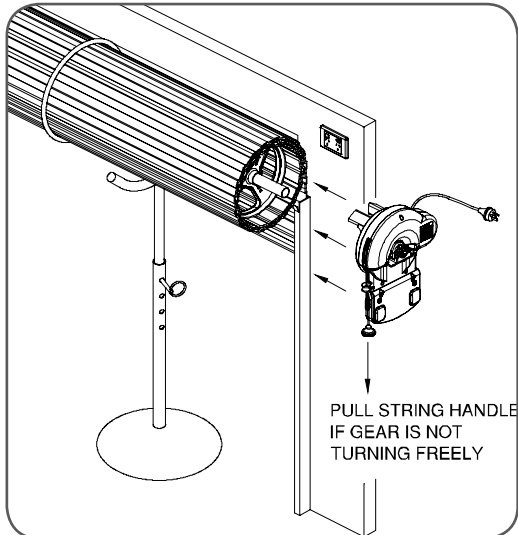
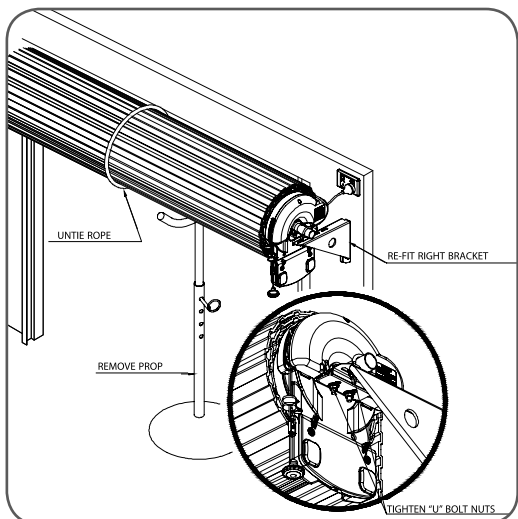

fig 10



Step 5 - Mounting the Opener

- a. If the internal gear does not rotate freely switch the opener to manual by pulling the disengagement handle down (there will be a click), so that the ring gear can be rotated by hand.
- b. Slide the opener over the door axle and into the drum of the door (**Fig. 09**).
- c. Ensure the internal gear is pushed in as far as possible (without interfering with the door curtain) and that one of the door drum's wheel spokes is completely between the opener's drive forks.
- d. Re-attach the door bracket using your reference marks as a guide and tighten the bolts. Ensure that the slots in the mounting bracket of the opener align with the slots in the door bracket, otherwise the door bracket may have to be relocated (**Fig. 10**).
 - » If the bracket cannot be relocated, the opener may be fitted onto the axle using the opener's saddle and U-bolt as follows:
 - i. Using your reference marks as a guide, sit the opener on the door mounting bracket and secure with the opener's U-bolt and saddle and tighten firmly.
 - ii. Adjust the door position (if necessary) on the brackets so that the door feeds smoothly into the guides. Make sure that the centre of the door doesn't hit the lintel and that the curtain is not pushed forward hard into the guide.
- e. Remove the support and safety ropes (**Fig. 10**).



IMPORTANT NOTE - If the manual release handle is more than 1.8 metres from floor level when the opener is installed, extend the handle to a height less than 1.8 metres.

- f. Connect the power cord to a suitable power point, but **DO NOT SWITCH ON**. Secure the power cord away from any moving object (e.g. the door) with the cable clip supplied.
- g. With the opener still disengaged, pull the door up and down to make sure it runs freely



Setting Limits

Step 6.1 - Setting Travel Limits

NOTE: If P.E. Beams are to be used they must be installed before setting the travel limits.



WARNING! Use caution when operating the manual release with the door open since it may fall rapidly due to weak or broken springs, or an improperly balanced door.



CAUTION! Do not disengage the opener to manual operation with children, persons or any objects including motor vehicles within the doorway.

- Move the door to half way open. If necessary, disengage the opener by pulling the cord down (**Fig. 11**).
- Re-engage the opener by pulling the cord down.
- Turn on the power to the opener. The CLOSE LIMIT LED will be flashing.
- Press and hold the CLOSE button - the door should starting closing (**Fig. 12**).
 - » If the door opens, release the CLOSE button and press the OPERATE button once to change the motor's direction. Press the CLOSE button again to close the door.
- Release the CLOSE button when the door is near the desired closed position. Single presses of the CLOSE button will "inch" the door closed.
 - » If the door overshoots press the OPEN button to move the door in the open direction.
- When the door is at the desired close position, press the SET button to record the close limit position. The OPEN LIMIT LED will now flash.
- Press and hold the OPEN button to open the door
- Release the OPEN button when the door is near the desired open position. Single presses of the OPEN button will "inch" the door open.
 - » If the door overshoots press the CLOSE button to move the door in the open direction.



WARNING! Once the next step is performed, the door will automatically close and open to calculate force settings. Keep persons and objects clear of the door until it stops and the opener sounds a beep.

- Press the SET button to store the open limit. **Please read the above warning.**

Step 6.2 - Resetting Travel Limits

To reset the limits press and hold the CLOSE button for 6 seconds until the CLOSE LIMIT LED flashes quickly. If no action is taken within 30 seconds, the opener will return to normal operating mode and restore the original limit settings.

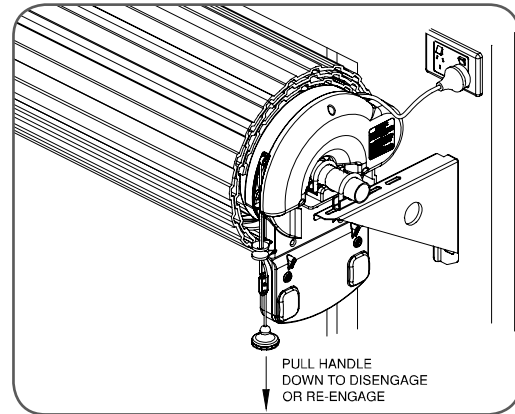

fig 11

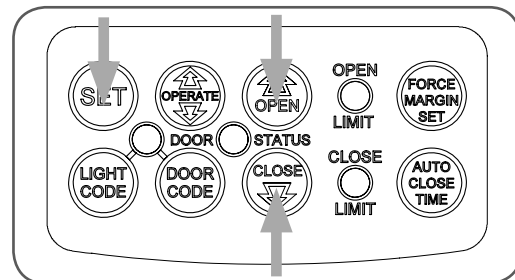

fig 12





Setting Limits: via Transmitter

fig 13

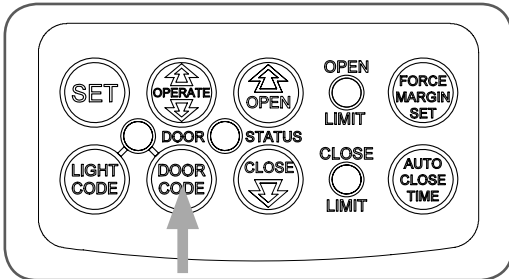

The GDO-6v3 has the alternate ability to set travel limits using the transmitter, allowing free movement around the garage to better assess the desired limit positions.

Step 7.1 - Code a Transmitter for Limit Setting

- Ensure the opener is powered up.
- Press and hold the DOOR CODE button (Fig. 13).
- Press Button 1 on the transmitter for two seconds (Fig. 14). Release and pause for two seconds. Press the Button 1 again for two seconds.
- Release the DOOR CODE button.

fig 14

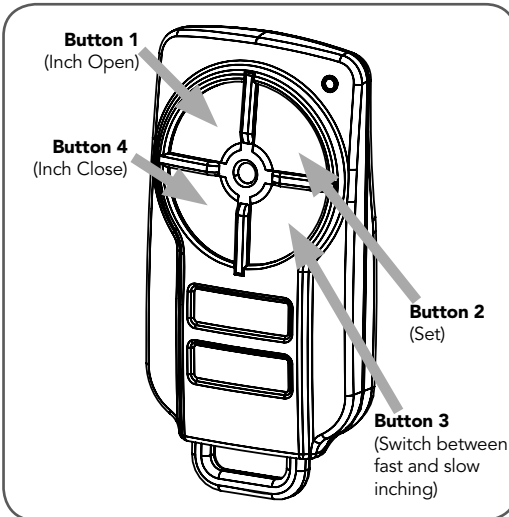

Step 7.2 - Setting Limits via Transmitter

- Press and hold Button 4 on the transmitter to close the door. When the door is approx. 2cm from the ground, press and hold Button 3 for two seconds and release (Fig. 14).
 - » If the door opens, release the CLOSE button and press the OPERATE button once to change the motor's direction, then repeat Step 7.2(a)
- Each press of Button 4 will allow you to "inch" the door closed. Keep doing this until the door reaches the desired close limit position.
 - » If the door is closed too far, press Button 1 to "inch" the door towards open
- When happy with the close limit position, press Button 2 to store this in memory.
- Press Button 1 to open the door. When approx. 2cm from the desired open position, press and hold Button 3 for two seconds then release.
- Each press of Button 1 will allow you to "inch" the door open. Keep doing this until the door reaches the desired open limit position.
 - » If the door is opened too far, press Button 4 to "inch" the door towards closed



IMPORTANT WARNING: The door will automatically close, open and close again **once Step 7.2(f) is performed**. Ensure that no persons or objects are in the door's path.

- When happy with the open limit position, press Button 2 on the transmitter to store into memory.
- The door will now automatically close and open to calculate the safety obstruction settings. After this, the opener can be operated with the OPERATE button.

Step 7.3 - Resetting the Door Limit Positions

- Limit positions can be deleted by the following steps:
- Follow Steps 15.5 (a) and (b), as outlined overleaf.
 - Repeat Steps 16.1 and 16.3 to set new travel limit positions.
 - » There is no need to re-code the transmitter (Step 16.2) upon resetting travel limits. The transmitter will still be stored in memory.





Safety Obstruction Force Test



WARNING! Take care when testing or adjusting the Safety Obstruction Force. Excessive force may cause **SERIOUS PERSONAL INJURY** and/or **PROPERTY DAMAGE**.

Step 8.1 - Testing Close Cycle

- Press the OPERATE button to open the door (**Fig. 15**).
- Place a piece of timber approximately 40mm high on the floor directly under the door (**Fig. 16**).
- Press the OPERATE button to close door. The door should strike the object and start to re-open.

Step 8.2 - Testing Open Cycle

- Press the OPERATE button to close the door (**Fig. 15**).
- Press again to open the door. When the door reaches the half open point, grab the bottom rail of the door firmly and the door should stop.
- If the door does not reverse readily when closing, or stop when opening, the force may be excessive and need adjusting, refer below.



DANGER! If the door fails these tests, put the opener into manual mode, only operate the door by hand and call for service.

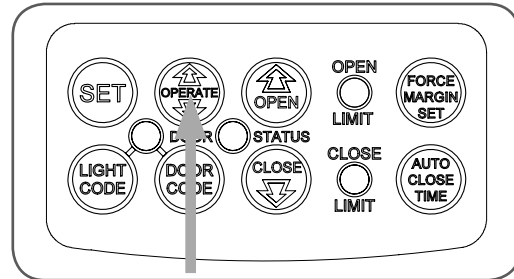

fig 15

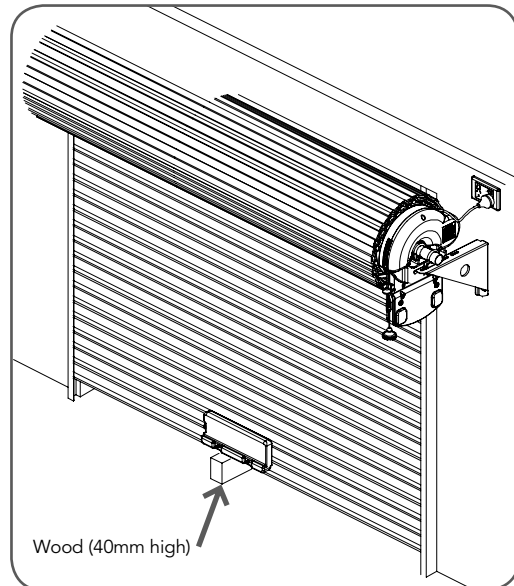

fig 16





Adjusting Safety Obstruction Forces

fig 17

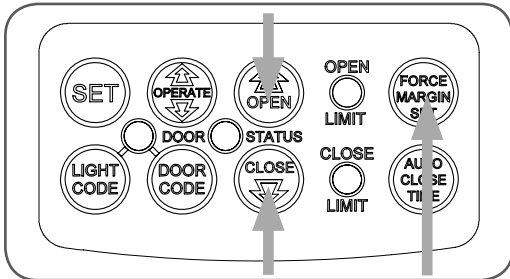

fig 18

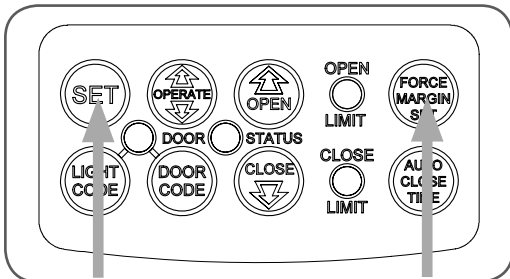
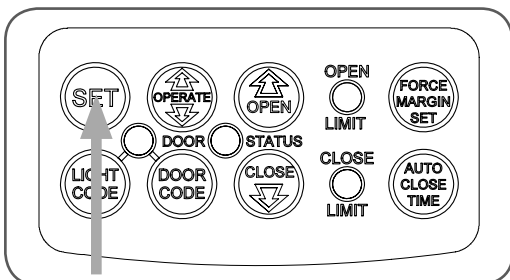

fig 19



Adjusting Safety Obstruction Force

The Safety Obstruction Force is calculated automatically during setup. Adjusting this is normally only necessitated by environmental conditions such as windy or dusty areas, and areas with extreme temperature changes.



WARNING: Doors requiring over 400N of force to move must have P.E. Beams fitted for safety.

Step 9.1 - To Increase Force Pressure

- Hold down FORCE MARGIN SET button (**Fig. 17**)
- While holding the FORCE MARGIN SET button, press the OPEN button. Each press increases the force margin.
- The OPEN LIMIT LED will flash each time the OPEN button is pressed to indicate a force increase
 - If the OPEN LIMIT LED flashes continuously when pressing the OPEN button this indicates that the maximum setting has been reached.
- Test the force again as per Steps 8.1 and 8.2

Step 9.2 - To Decrease Force Pressure

- Hold down FORCE MARGIN SET button (**Fig. 17**)
- While holding the FORCE MARGIN SET button, press the CLOSE button. Each press decreases the force margin.
- The CLOSE LIMIT LED will flash each time the CLOSE button is pressed to indicate a force increase
 - If the OPEN LIMIT LED flashes continuously when pressing the OPEN button this indicates that the maximum setting has been reached.
- Test the force again as per Steps 8.1 and 8.2

Step 9.3 - To Recall Factory Set Force

- While holding down the FORCE MARGIN SET button, press the SET button for two (2) seconds. (**Fig. 18**)
- Release both buttons. The default setting should now be recalled.

Step 9.4 - To Recalculate Force Margins

- Press and hold the SET Button for two (2) seconds, the beeper will sound once (**Fig. 19**).
- The door will start to move and re-calculate force margins. The door can move between the open and close limit positions up to four (4) times (depending on the position of the door and the power up condition).
- A single beep will be heard once the process is complete.
- Test the force again as per Steps 8.1 and 8.2.



Coding Transmitters

Step 10.1 - Code a Transmitter Button for Door Operation

- Press and hold the DOOR CODE button (**Fig. 20**).
- Press one of the four buttons on the transmitter for two (2) seconds, pause for two (2) seconds, then press the same button again for two (2) seconds.
- Release the DOOR CODE BUTTON.
- Press the transmitter button to test.

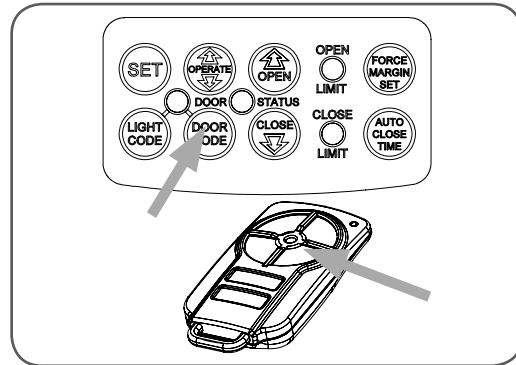

fig 20

Step 10.2 - Coding a Transmitter Button to the Courtesy Light

The transmitter can be programmed to operate the courtesy light on the opener independently of the door moving.

- Press and hold LIGHT CODE button (**Fig. 21**).
- Press one of the four buttons on the transmitter for two (2) seconds, pause for two (2) seconds, then press the same button again for two (2) seconds.
- Release the LIGHT CODE button.
- Press the transmitter button to test.

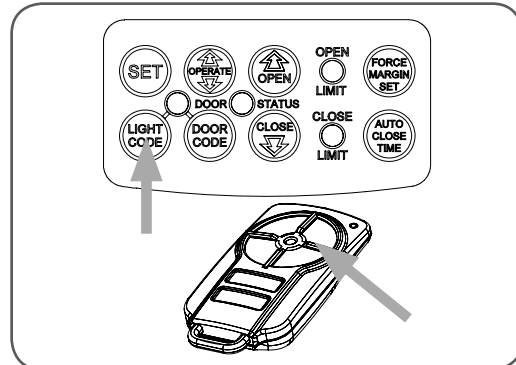

fig 21

Step 10.3 - Code a Transmitter Button for Pet (Pedestrian) Mode

- Press and hold both the DOOR CODE and CLOSE buttons (**Fig. 22**).
- Press one of the four buttons on the transmitter for two (2) seconds, pause for two (2) seconds, then press the same button again for two (2) seconds.
- Release the DOOR CODE and CLOSE buttons.
- Press the transmitter button to test. To change the default pet (pedestrian) door opening position, refer Step 2.

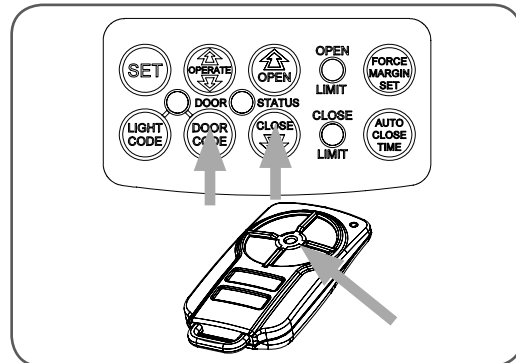

fig 22

Step 10.4 - Code a Transmitter Button to Enable Vacation mode

The opener can be programmed into a "Vacation Mode" where the opener will not respond to any transmitter except one preprogrammed unit.

- Press and hold LIGHT CODE and CLOSE buttons (**Fig. 23**).
- Press one of the four buttons on the transmitter for two (2) seconds, pause for two (2) seconds, then press the same button again for two (2) seconds.
- Release LIGHT CODE and CLOSE buttons.
- To test, press and hold the transmitter button for five seconds to set Vacation Mode.
- To reset Vacation Mode press the same button for two seconds.

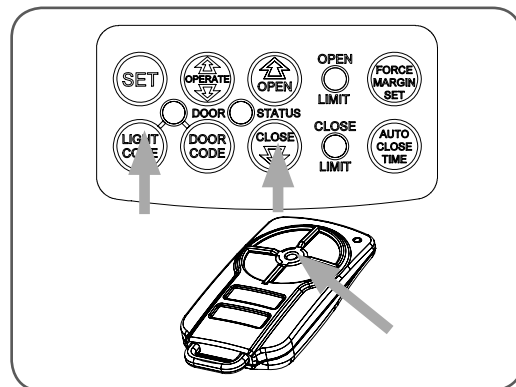

fig 23





Coding Transmitters

fig 24

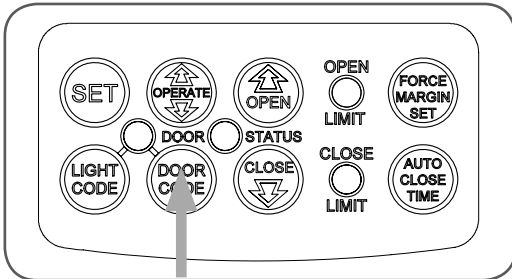

Step 11 - Easy Access Transmitter Coding

- Press and hold the DOOR CODE button (Fig. 24).
- Press the EAT's button two (2) seconds, pause for two (2) seconds, then press the button again for two (2) seconds (Fig. 25).
- Release the DOOR CODE button.
- Press the transmitter button to test.

fig 25

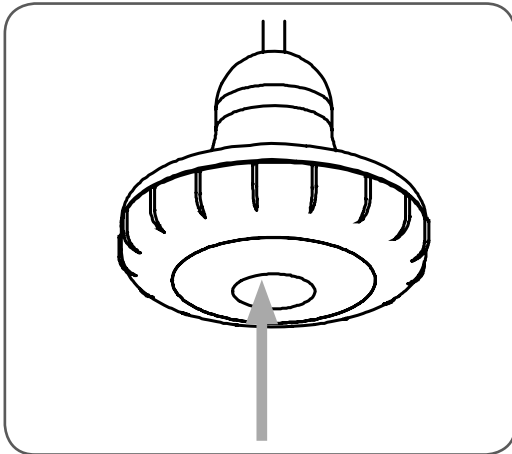

Step 12 - Remotely Coding Transmitters

Using this method transmitters can be coded without access to the opener's control panel as long as a pre-coded transmitter is available.



IMPORTANT NOTE: The door or courtesy light must activate when the steps below are performed. This indicates that the pre-coded transmitter is in range of the opener, and the correct button has been pressed.

fig 26

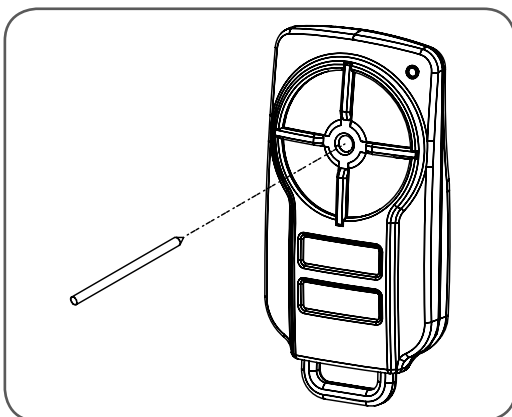

- Take any pre-coded transmitter. Press the button for the function to be duplicated and release.
- Using a small needle, press and hold firmly for two seconds through the Coding Hole (Fig. 26).
- WITHIN 10 SECONDS take the additional transmitter you wish to code. Decide which button that you want to activate the function to be duplicated (e.g. activate the door, or turn on the courtesy light)
- Hold the new transmitter's button for two seconds, pause for two seconds, hold again for two seconds and then release.
- Wait for 10 seconds and then press the new transmitter's button to test.





Deleting Transmitter Codes

Step 13.1 - Deleting a Stored Transmitter Code

- Select the transmitter you want to delete.
- Press and hold the DOOR CODE BUTTON (**Fig. 27**).
- Press the transmitter button you would like to delete for two seconds, pause for two seconds, press again for two seconds and then release.
- Release the DOOR CODE BUTTON. The code should now be deleted. Confirm this by pressing the transmitter button - the function (e.g. door opening) should not respond.

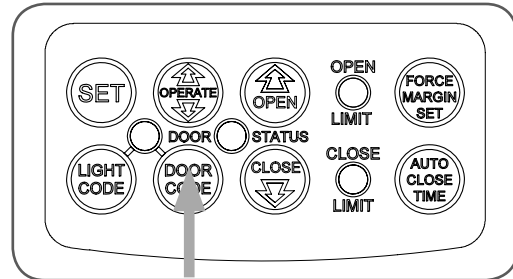

fig 27

Step 13.2 - Deleting All Transmitter Codes

1. Turn off power to the opener.
- While switched off, press and hold the DOOR CODE BUTTON (**Fig. 27**). Turn on power to the opener while holding this button.
- The OPEN LIMIT, CLOSE LIMIT and DOOR STATUS LEDs will illuminate for about five seconds. These LED's will turn off and the CODING LED will illuminate.
- Release the DOOR CODE BUTTON. All stored codes will now be deleted. Confirm this pressing buttons on any previously coded transmitters - the opener should not respond.





P.E. Beams & Auto-close

fig 28

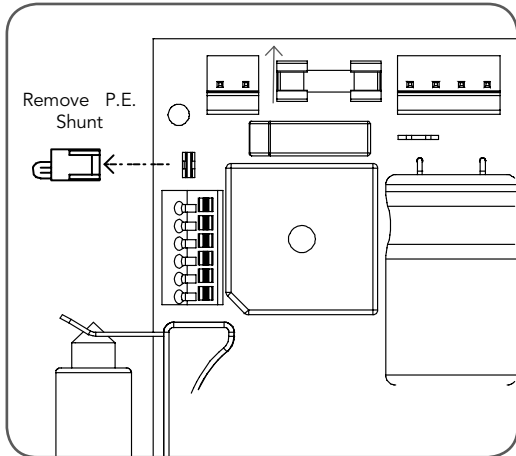

Step 14 - Fitting the P.E. Beams (optional)

- Affix the P.E. Beams in a strategic location within the doorway. We recommend 150mm above the floor level and as close as possible to the door opening, inside the garage.
- Remove the shunt from P.E connector (**Fig. 28**).
- Connect the wires from the P.E. wiring harness to terminal block (**Fig. 29**). The wiring diagram is for Model PHBE (Order Code 90214).

Make sure to align the beams correctly. Follow the manual supplied with the P.E. Beams.



WARNING: When using Auto Close Mode and P.E. beams, the doorway must be clear of all obstructions and persons at all times. The location of the beam and manner in which it is installed might not give safety protection at all times. Check to make sure that the height of the beam and type used give maximum protection possible.

fig 29

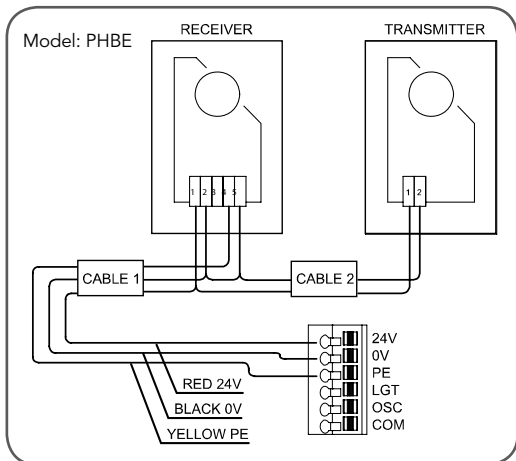

Step 15 - Setting Up Auto-close Mode



IMPORTANT NOTICE: It is compulsory to have P.E. Beams installed when using Auto-close mode.

Auto-close mode is a function that automatically closes the door a preset time after the P.E. Beams recognise that a vehicle has left the garage.

The Auto-close timer only starts after the P.E. Beam's path is broken the Auto-close timer has been set. If the P.E. path is not broken the door will remain open until the path is broken. If the opener incurs a physical obstruction (i.e. not from the P.E. Beams) while closing the door will re-open and not Auto-close until the P.E. Beam's path is broken again.

fig 30

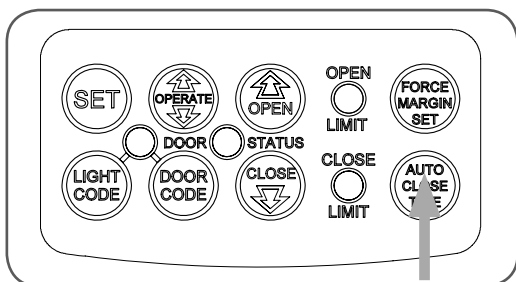

Step 15.1 - Setting Auto-close Time

- Hold down the AUTO CLOSE TIME button (**Fig. 30**).
- While holding in the AUTO CLOSE TIME button, press the OPEN button - each press will add one second to the Auto-close delay.
- To decrease the delay time follow Step 15.1(a) and press the CLOSE button - each press will deduct one second from the Auto-close delay.
- Press the OPERATE button or transmitter to open the door. When the door is fully opened the OPEN LIMIT LED will flash to indicate that Auto-close mode is operational.
- Break the P.E. Beam's path momentarily to initialise Auto-close. When the door reaches the fully opened position, the door will pause for the set Auto-close time and then close.





Final Set Up

Step 16 - Setting of Courtesy Light Time

The preset courtesy light time is three minutes. This time can be changed by the following:

- Press and hold both the AUTO CLOSE TIME and FORCE MARGIN SET buttons (**Fig. 31**).
- While holding in these buttons, press the OPEN button - each press will add 10 seconds to the light time.
- To decrease the time, follow Step 16(a) and press the CLOSE button - each press will deduct 10 seconds from the light time.
- To recall the factory set light time press and hold together the AUTO CLOSE TIME button, the FORCE MARGIN SET button and the SET button for 2 seconds.

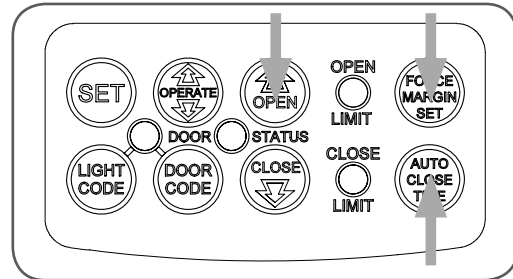

fig 31

Step 17 - Setting the Pet Mode position

The default Pet Mode height can be changed as follows:

- Make sure the door is closed, then press and hold the OPEN button for six (6) seconds (**Fig. 32**), until you hear three beeps and the OPEN and CLOSE LEDs flash rapidly.
- Press the OPEN or CLOSE button to move the door to the desired pet mode open position.
- Press the SET button to record the new position.

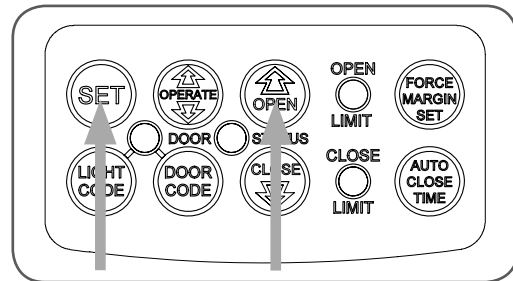

fig 32

When activated, Pet Mode drives the door to the preset position from either above or below. Pet Mode's active status is indicated by both the OPEN and CLOSE LIMIT LEDs being illuminated. If a Pet Mode button is pressed while the door is moving the door will stop. If a Pet Mode button is pressed when the door is in the Pet position, then the door will close.

Step 18 - Installing the Wall Mounted Transmitter (Optional)

- Remove the faceplate from the transmitter.
- Affix the baseplate in a convenient wall location that is out of reach of children and convenient to the customer (**Fig 33**). Make sure the door is visible from this location.
- Replace the faceplate.
- To code the transmitter, see Steps 10.1 through 10.4 on page 19.

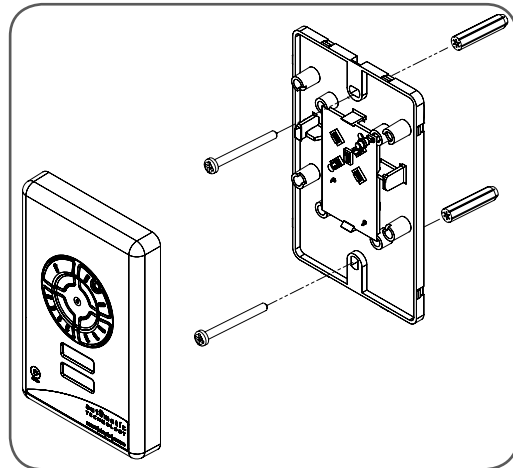

fig 33

Step 19 - Reset all Factory Defaults

- Turn power to opener off.
- Press and hold the SET Button (**Fig 33**).
- Turn power on while holding the SET button. Continue to hold until all LEDs are off.
 - » This will not erase transmitter codes stored in memory.

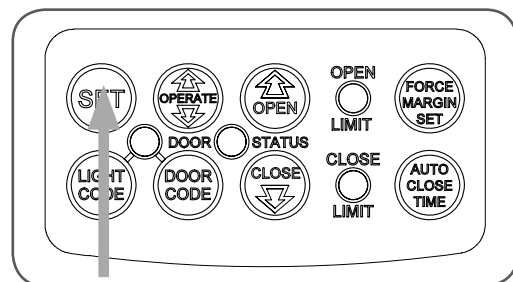

fig 34





SmartSolar™ Installation

Fig 35

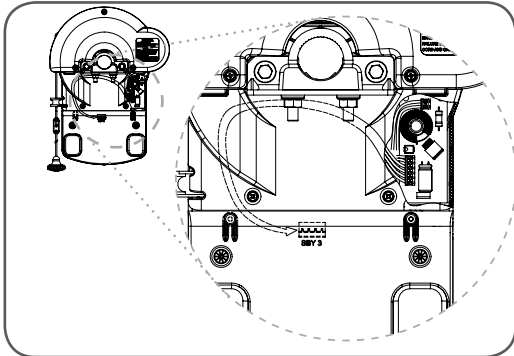

WARNING: Do not connect the batteries until after Step 20.2.

Step 20.1 - Mount the Charger Board

1. Unplug the drive unit from mains power.
2. Disengage motor using manual release cord.
3. Remove the main cover, timing cover and light diffuser, then remove the transformer, EMC board and mains power cable.
4. Fix the Charger Board under the timing cover using four (4) M4x8 screws (**Fig. 35**).
5. Feed the four wire cable through the opening, then connect the three wire harness (red/yellow/black) into the control board's "SBY-3" connector (**Fig. 36**).
6. Plug the one wire harness (white) into the control board's "24vac in" connector on (**Fig. 36**).
7. Plug the solar shunt (supplied) onto the control board's "J13" connector (**Fig. 36**).

Fig 36

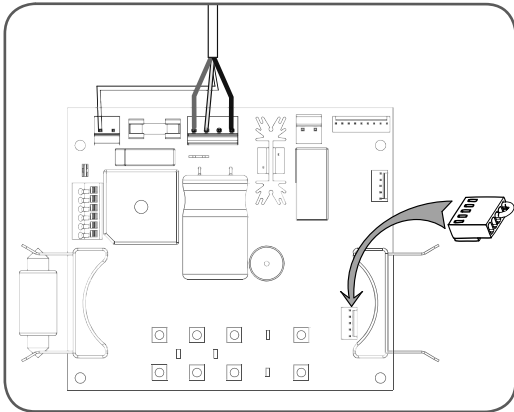

IMPORTANT WARNING: Do not connect battery or solar panel polarity incorrectly - this will result in serious damage to components.

Step 20.2 - Connect the Solar Panel

1. Mount the solar panel as described in the SmartSolar™ Instruction Manual
2. Feed the Solar Panel's cable through black grommet on the chassis.
3. Connect the **red wire** to the Charger Board's "**SOLAR+**" connector, and the **black wire** to the "**-SOLAR**" connector (**Fig. 37**).

Fig 37

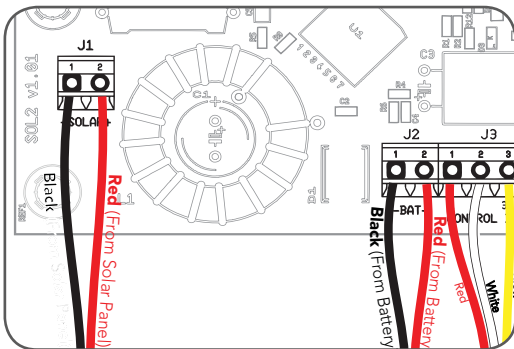

WARNING: During Step 20.3 the opener will become active.

Step 20.3 - Mount & Connect the Battery

1. Mount the Battery Box close to the opener.
2. Feed the 2-core 18awg gauge cable (supplied) through the Battery Box's grommet.
3. Connect the **red wire** to the Battery Box's "+" terminal, and the **black wire** to the "-" terminal (**Fig. 38**).
4. Feed the other end of the battery cable through the drive unit's black grommet.
5. Connect the **red wire** to the Charger Board's "**BAT+**" connector, and the **black wire** to the "**-BAT**" connector (**Fig. 37**).
6. Refit the timing cover, main cover and light diffuser.

Fig 38

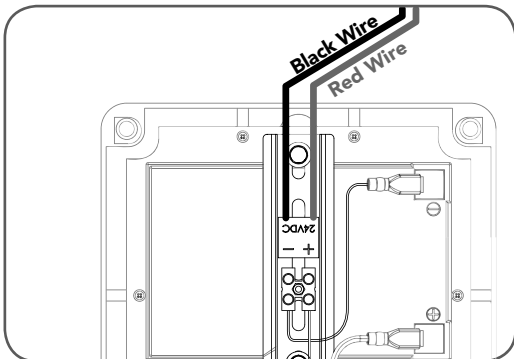

Step 20.4 - Re-setup and Test the Opener

1. Setup travel limits and code transmitters as per the GDO-6 instruction manual.
2. Press either the OPERATE button, or use a transmitter to operate the opener.





Battery Back Up Kit Installation

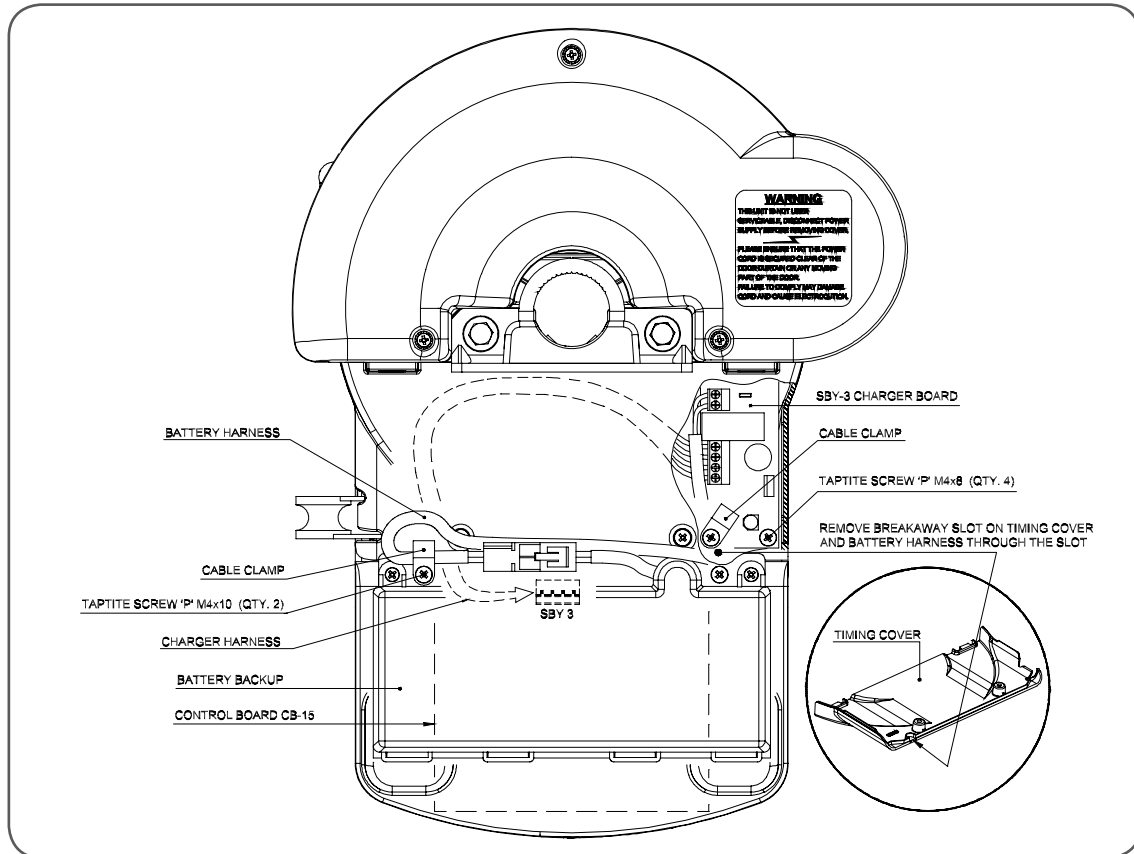

Fig 39

Step 21.1 - Connect the Battery Back Up Kit

- Turn off power to the opener and disengage motor.
- Remove timing cover and light diffuser.
- Remove cable clamp and screw (Fig. 39). Retain cable clamp for later use.
- Mount the SBY-3 Charger Board on base and secure with four (4) Taptite 'P' M4 x 8 screws.
- Secure lower left corner with cable clamp holding brown transformer wires.
- Feed 4-Wire harness around timing assembly, through opening and plug into control board's SBY-3 connector (Fig. 39).
- Remove breakaway slot on timing cover.
- Feed 2-wire battery harness through slot and replace timing cover and secure in place with screws.
- Mount Battery Back Up Kit onto support chassis and secure right side screw first (charger board side).
- Position 2-wire battery harness neatly and secure left side of battery kit with cable clamp.



WARNING: After Step 21.1(k) the opener may become active (even when power is off). This is a result of a residual charge in the batteries.

- Connect battery harness together (Fig. 39).
- Reconnect power and re-engage the motor.

Step 21.2 - Testing the Battery Back Up Kit.

- Press either the OPERATE button or transmitter button to activate the door.
- Whilst the door is in motion disconnect mains power. When mains power is cut, the Battery Back Up Kit should respond to the shut down. The door should continue operating as normal.



NOTE: Wait for the door to complete its travel.

- Press OPERATE or a transmitter button to activate the door.
- Whilst door is in motion re-connect power. The door should complete the cycle as normal. Unplug the drive unit from mains power.





Parameters

Door Status Indicators

Door Opener State	OPEN LED (Green)	CLOSE LED (Red)	Beeper
Open	On		
Close		On	
Opening	Flashing		
Closing		Flashing	
Door travel stopped	Flashing	Flashing	
Door obstructed when opening	Flashing		
Door obstructed when closing		Flashing	Beeps as door moves
Opener overloaded	Alternating flashes	Alternating flashes	
Door in open position with Auto-Close mode selected	One second flashes		
Pet Mode Engaged	On	On	
Mains power interrupted	Rapid flashes		





Parameters

Button Functions

Buttons	Function
OPERATE	Opens/Stops/Closes the door
DOOR CODE	Codes a transmitter button for operate function
LIGHT CODE	Codes a transmitter button for light function
DOOR CODE & CLOSE	Codes a transmitter button for pet mode
LIGHT CODE & CLOSE	Codes a transmitter button for vacation function
FORCE MARGIN SET & OPEN	Increases the obstruction force margin setting
FORCE MARGIN SET & CLOSE	Decreases the obstruction force margin setting
FORCE MARGIN SET (then) SET	Resets the factory default force margin settings
AUTO CLOSE TIME (then) OPEN	Increases the auto close delay time
AUTO CLOSE TIME (then) CLOSE	Decreases the auto close delay time
AUTO CLOSE TIME (then) SET	Resets the factory default auto close delay time
FORCE MARGIN SET & AUTO CLOSE TIME (then) OPEN	Each press of the OPEN button increases the light time by 10 secs.
FORCE MARGIN SET & AUTO CLOSE TIME (then) CLOSE	Each press of the CLOSE button decreases the light time by 10 secs.
FORCE MARGIN SET & AUTO CLOSE TIME (then) SET	Reloads the factory default light time
CLOSE (for 6 secs.)	Clears the door limits set positions. Limits then need to be reset
SET & CLOSE (for 2 secs.)	Enters pet (pedestrian) position mode
SET (then power on) & hold until all LEDs are off	Deletes control parameters excluding transmitter storage memory
DOOR CODE (then power on) & hold until all LEDs are off	Deletes all transmitter storage memory
SET & DOOR CODE (the power on) and hold until all LEDs are off	Deletes all control parameters and transmitter storage memory.
SET	Re-initialises the Opener to re-calculate force margin





Default Settings & Specifications

Factory Default Settings

	Default	Step	Maximum
Maximum motor run time	25 secs	-	-
Courtesy light time	3 mins	10 secs	10 mins
Obstruction force margin	8	1	20
Auto close time	0 secs	1 secs	4 mins

Technical Specifications

Power supply	230V - 240Va.c. 50Hz
Standby power	1.8 Watts
Motor power	100 Watts
Motor type	24Vd.c. Permanent Magnet
Controller Voltage	24Vd.c.
Maximum door opening:	Width: 5500mm Height: 2700mm Weight: 100kg
Opener Limits Travel	3.0 turns of Door Drum Wheel
Receiver type	UHF Multi-frequency FM Receiver
Receiver code storage capacity	24 X 4 button Transmitter Codes
Transmitter frequency	UHF Multi-frequency FM Transmitter
Coding type	Code hopping
Number of code combinations	Over 4.29 billion random codes
Code generation	Non-linear encryption algorithm
Courtesy light	Festoon Type - 15W 24Vd.c.
Controller fuse	10A slow blow

NOTE:

1. The door must be well balanced. A person should be able to lift the door up manually with very little effort in case of an emergency.
2. Intermittent operations may occur in areas which experience very strong winds. Strong wind puts extra pressure on the door and tracks which may in turn trigger the safety obstruction detection system intermittently.





Troubleshooting

Symptom	Possible cause	Remedy
Door will not operate	Mains power not switched on.	Switch on mains power.
	Door is obstructed.	Remove obstruction.
	Door is locked or motor jammed.	Unlock door or remove jam.
	Door tracks/hardware damaged.	Door requires service/repair by qualified technician.
	The opener is in "vacation mode"	Turn off "vacation mode".
Door starts to close but automatically reverses to open position	Adverse weather conditions (wind or cold) causing door to stiffen and become tight in the tracks.	Increase force margin setting See page 18 or re-calculate force margin.
	Possible obstruction in the doorway.	Remove obstruction.
Door operates from drive unit (OPERATE) button but not from transmitter* See note	Transmitter code not stored in memory.	Code transmitter in to openers memory. Refer step 10.1 on page 19
	Flat battery.	Replace battery
	Broken battery lead inside transmitter	Send transmitter to installer or Automatic Technology for repair
Door will not close fully.	Door limits positions need to be reset.	Reset limits positions. Step 7.3, page 16.
Door will not open fully.	Door limits positions need to be reset.	Reset limits positions. Step 7.3, page 16.
Courtesy light not working	Globe down	Replace globe
Globe keeps blowing	Incorrect globe voltage - must be 240V AC	Replace globe
Auto close not working	PE Beam or wiring faulty.	Repair PE Beam or replace wiring.
	PE Beam not aligned correctly.	Re-align optics.
	PE Beam is obstructed.	Remove obstruction from path of PE.
	Door obstructed when closing.	Remove obstruction.
	Auto close time not set.	See Step 15 on page 22.
	Auto close mode not set	See Step 15 on page 22.

PLEASE NOTE:

Some areas may be prone to excessive radio interference brought on by devices such as cordless telephones, wireless stereo headphones and baby monitors. It is possible that these devices could cause a degree of interference such as to greatly reduce the range of the transmitter. In such an instance please contact your Automatic Technology dealer for an alternative frequency replacement kit. As this is not a warrantable situation but an environmental issue charges may apply for the change-over.





smart | simple | secure





Spare Parts

ITEM NO.	DESCRIPTION	ORDER CODE
1	DRIVE CHASSIS	03011
2	CLUTCH GEARED MOTOR ASSY 12-01	00373
3	HEX SERRATION HEAD SCREW M6x16	10170
4	TRANSFORMER TDB-100-143 KIT	02022
5	CORD GRIP GROMMET SB5P-2	05606
6a	POWER CORD A.S. 1.5M W2P+1R	14150
6b	POWER CORD B.S. 1.5M W2P+1R	05667
6c	POWER CORD E.U. 1.5M W2P+1R	05679
6d	POWER CORD S.A. 1.5M 15A W2P+1R	05673
7	EMC FILTER BOARD EMC-2.02	01443
8	WIRE EARTH ASSY 250L	12150
9	PAIN HEAD SCREW/W/WASHER M4x8	10330
10	MOUNTING BRACKET VRT	02504
11	HEX SERRATION HEAD SCREW M8x16	10122
12	SUPPORT CHASSIS	16205
13	GROMMET 10142Z	05603
14	TIMING ASSY	01732
15	TIMING HARNESS ASSY	01791
16	STRING GUIDE	16420
17	CONTROL BOARD DCB03	00802
18	DUST COVER BOTTOM	03222
19	DUST COVER TOP	03223
20	TAPTITE SCREW 'P' M4x10	10570
21	TAPTITE SCREW 'P' M4x6	10562
22	INTERNAL GEAR	16020
23	CLAMP WASHER	11180
24	RETAINING RING STW 45	10650
25	EASY ACCESS TRANSMITTER PACK TRI-CODE	13020
26	LITHIUM BATTERY 3V	15441
27	STRING 1.2M	15995
28	STRING ADJUSTER	15995
29	LABEL RELEASE	13656
30	MAIN COVER ASSY	16256
31	TIMING COVER	03225
32	GLOBE 24V/15W	05440
33	LIGHT DIFFUSER ASSY V2	05111
34	CONTROLS LID COVER	05103
35	INDUSTRIAL SADDLE	03175
36	U-BOLT M8	10141
37	HEX SERRATION FLANGE NUT M8 (BLACK)	10148
38	FLAT WASHER 8.4x18x1.6	11021
39	TAPTITE SCREW 'P' M4x8	10580
40	PAIN HEAD SCREW/W/WASHER M4x10	10340
41	TRANSMITTER PTX-5	01170
42	WALL TRANSMITTER VTX-4	01195
43	LITHIUM BATTERY 3V CR203	13021
44	COVER WITH D/S TAPE	71040
45	WEIGHT BAR	71190
46	WEIGHT BAR ACCESSORY PACK	01782
47		

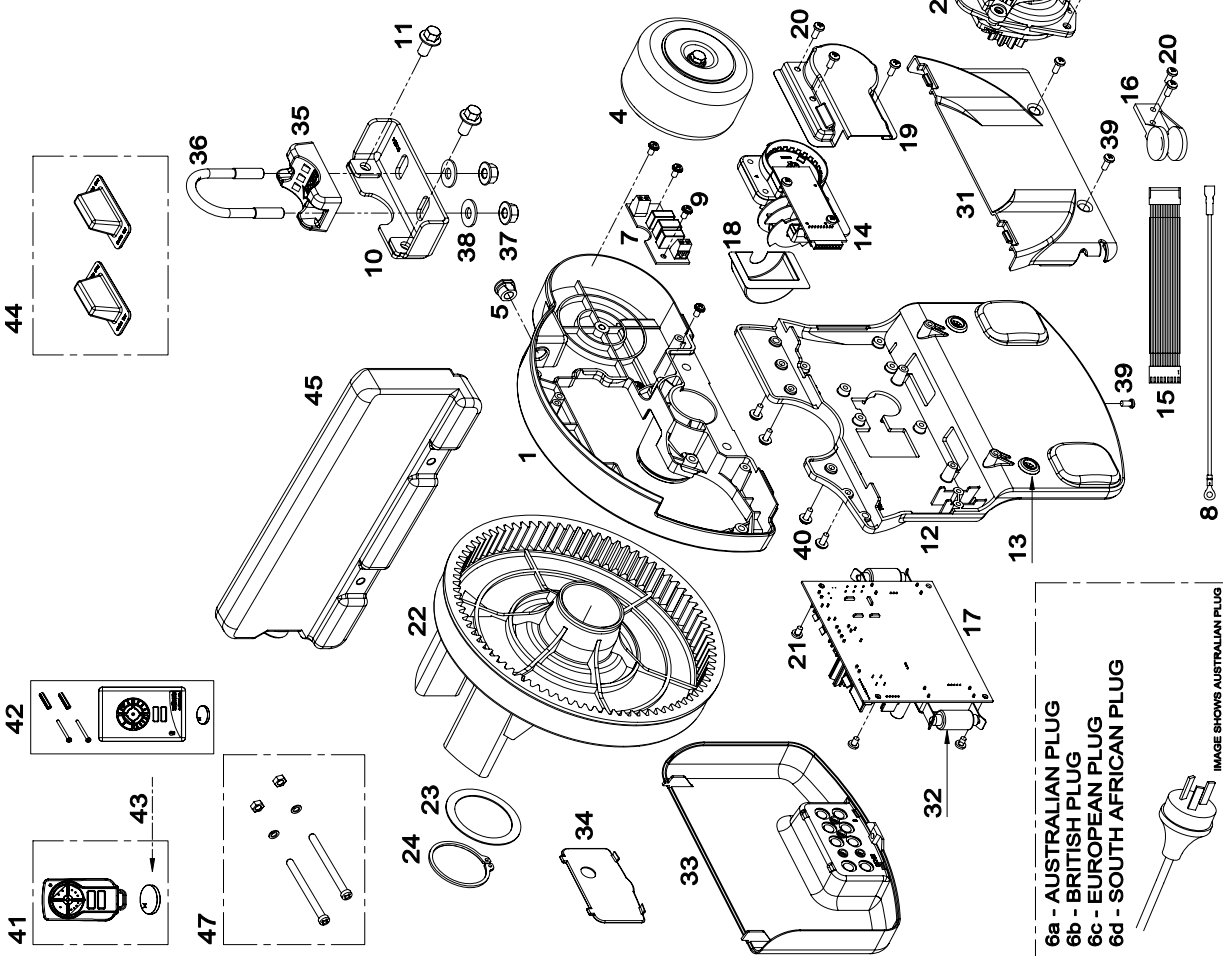

6a - AUSTRALIAN PLUG
 6b - BRITISH PLUG
 6c - EUROPEAN PLUG
 6d - SOUTH AFRICAN PLUG

IMAGE SHOWS AUSTRALIAN PLUG

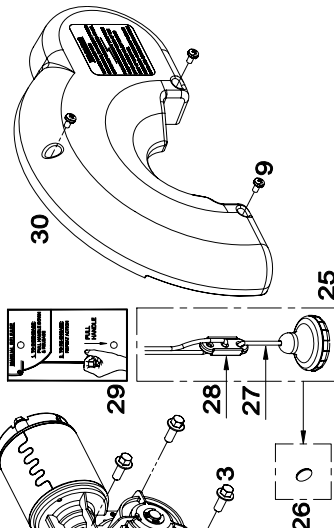



smart | simple | secure





Warranty and Exclusion of Liability

1. This warranty is an addition to any non-excludable conditions or warranties that are implied into this contract by relevant statute, including the Trade Practices Act 1974 (Cwth).
2. Subject to all of the matters set out below, Automatic Technology Australia Pty Ltd ("ATA") warrants:
 - (a) overhead door opener drive units for twenty four (24) months or 5000 cycles, whichever occurs first; and
 - (b) all components and accessories for twelve (12) months, from the date of purchase (specified in the sales docket receipt) as free of any defects in material and workmanship.
3. This warranty applies only where the purchaser:
 - (a) immediately notifies ATA or the retailer of the alleged defect;
 - (b) returns the product to the retailer; and
 - (c) presents the relevant sales docket and this warranty document to the retailer to confirm the date of purchase.
4. Except for this warranty, ATA gives no warranties of any kind whatsoever (whether express or implied), in relation to the product, and all warranties of whatsoever kind relating to the product are, to the extent permissible by statute, hereby excluded.
5. To the extent permissible by statute, ATA disclaims any liability of whatsoever nature in respect of any claim or demand for loss or damage which arises out of:
 - (a) accidental damage to or normal wear and tear to the product or to the product's components;
 - (b) any cost relating to damage resulting from wear and tear;
 - (c) blown fuses, loss or damage caused by electrical surges, power surges or power spikes;
 - (d) loss or damage due to theft, fire, flood, rain, water, lightning, storms or any other acts of God;
 - (e) maximum continuous operating time exceeding one (1) minute in ten (10);
 - (f) maximum operating force exceeding *20kg (200N) when moving the door manually to the open or closed position;
 - (g) door surface area and/or weight exceeding 16.5m² and 100kg respectively;
 - (h) door not in safe and correct working order and condition;
 - (i) evidence of unauthorised repairs;
 - (j) any cost relating to damage caused by misuse, negligence or failure to maintain the equipment in a proper working order as per clauses (d) through (h);
 - (k) installation, adjustment or use which is not in accordance with the instructions set out in installation instruction manual
 - (l) attempted or complete modification or repairs to the product carried out by a person who is not authorised or has not been trained by ATA to carry out such modification or repairs;
 - (m) faulty or unsuitable wiring of structure to which the product is fixed or connected;
 - (n) radio (including citizen band transmission) or any electrical interference;
 - (o) damage caused by insects;
 - (p) loss or damage to any property whatsoever or any loss or expense whatsoever resulting or arising there from or any consequential loss;
 - (q) any cost or expense arising due to manufacturer recall of any product;
 - (r) any cost or expense due to negligence of the approved service provider;
 - (s) installation of a residential garage door opener in a commercial or industrial situation or a non-single residential dwelling.
6. ATA's liability under this warranty is limited, at ATA's absolute option, to replacing or repairing the product which ATA, in its unfettered opinion, considers to be defective either in material and/or workmanship or to credit the dealer with the price at which the product was purchased by the dealer.
7. This warranty does not extend to cover labour for installation.
8. This warranty is limited to Return-to-Base (RTB) repair and does not cover labour for on-site attendance.
9. This warranty is void if the Product is not returned to the manufacturer in original or suitably secure packaging.
10. This warranty is only applicable for repairs to the product carried out within Australia.
11. This warranty does not cover consumable items including globes, batteries and fuses.
12. This warranty is not transferable.
13. Where the Product is retailed by any person other than ATA, except for the warranty set out above, such person has no authority from ATA to give any warranty or guarantee on ATA's behalf in addition to the warranty set out above.

NOTES:

1. One (1) cycle = one (1) open and one (1) close action of the door or gate.
2. This warranty is to be read in conjunction with the owner's copy of the installation instruction manual.
- 3 *The door should be balanced in such a way that the user manually is able to open or close the door without using force not greater than 150N (15kg) although a greater force may be required for the start of the movement.





smart | simple | secure





© January 2008 Automatic Technology (Australia) Pty Ltd. All rights reserved. TrioCode™ and EasyRoller® are trademarks of Automatic Technology (Australia) Pty Ltd. No part of this document may be reproduced without prior permission. In an ongoing commitment to product quality we reserve the right to change specification without notice. E&OE.

automatic
TECHNOLOGY

smart | simple | secure

an alesco company

Automatic Technology (Australia) Pty Ltd

ABN 11 007 125 368

6-8 Fiveways Boulevard
Keysborough, Victoria, 3173, Australia

P 1300 133 944

+61 2 9722 5666 (International Enquiries Only)

E sales@ata-aust.com.au

www.ata-aust.com.au